



Installation of Magnaloy Coupling Spline Bored/Steel Bushed/Clamp type hubs

Magnaloy manufactures its steel bushings from high quality steel bar stock. In some cases, this material has residual stresses in it and after the bushing is turned, milled and broached with the spline bore, the bushing collapses when it is slit for the clamp feature. During this slitting operation the coupling with bushing installed is inserted on a spline arbor matching the spline bore of the bushing. This provides a positive method to locate the spline teeth in relation to the slit and also provides assurance that the spline bore fits the shaft per specification. This condition has caused some installation issues which our customer service people and engineering staff has addressed with customers. In light of this, we are providing the following procedure for installation of these coupling hubs.

If the coupling hub does not install on the spline shaft readily. Please note there is not a great amount of clearance between the shaft and bore of these hubs, so attention in assembly is required.

1. Check the spline shaft size and the coupling spline bore size. This can be done quickly by counting the number of teeth and measuring the major diameter on each.
2. Loosen the Clamp Bolt and Set Screw in the coupling hub.
3. If the coupling still does not install on the spline shaft, the bushing may have collapsed.
4. Do not remove the steel bushing from of the coupling hub to perform this installation procedure. Opening the slit in the steel bushing excessively could cause damage to the steel bushing.
5. Use a small screwdriver or other wedged device and insert it into the bushing slit, as shown below, apply force to cause the bushing slit to open to original position.
6. Keep the screwdriver in this position and slide the coupling hub over the shaft and remove the screwdriver.
7. After positioning the coupling hub on the shaft, tighten the clamp bolt to the torque specified in the Magnaloy Coupling Catalog (page 11), then re-tighten the setscrew to its specified torque. Note the fastener tightening sequence: clamp bolt first then the set screw over the bushing keyway.

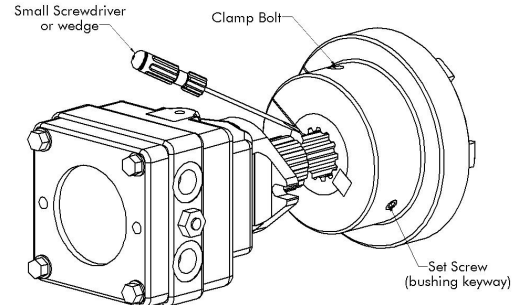

Installation of Magnaloy Coupling Spline Bored/Steel Bushed/Clamp type hubs

Magnaloy manufactures its steel bushings from high quality steel bar stock. In some cases, this material has residual stresses in it and after the bushing is turned, milled and broached with the spline bore, the bushing collapses when it is slit for the clamp feature. During this slitting operation the coupling with bushing installed is inserted on a spline arbor matching the spline bore of the bushing. This provides a positive method to locate the spline teeth in relation to the slit and also provides assurance that the spline bore fits the shaft per specification. This condition has caused some installation issues which our customer service people and engineering staff has addressed with customers. In light of this, we are providing the following procedure for installation of these coupling hubs.

If the coupling hub does not install on the spline shaft readily. Please note there is not a great amount of clearance between the shaft and bore of these hubs, so attention in assembly is required.

1. Check the spline shaft size and the coupling spline bore size. This can be done quickly by counting the number of teeth and measuring the major diameter on each.
2. Loosen the Clamp Bolt and Set Screw in the coupling hub.
3. If the coupling still does not install on the spline shaft, the bushing may have collapsed.
4. Do not remove the steel bushing from of the coupling hub to perform this installation procedure. Opening the slit in the steel bushing excessively could cause damage to the steel bushing.
5. Use a small screwdriver or other wedged device and insert it into the bushing slit, as shown below, apply force to cause the bushing slit to open to original position.
6. Keep the screwdriver in this position and slide the coupling hub over the shaft and remove the screwdriver.
7. After positioning the coupling hub on the shaft, tighten the clamp bolt to the torque specified in the Magnaloy Coupling Catalog (page 11), then re-tighten the setscrew to its specified torque. Note the fastener tightening sequence: clamp bolt first then the set screw over the bushing keyway.

